

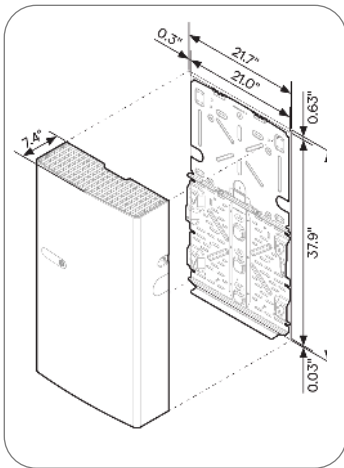

IQ Battery 5P

The IQ Battery 5P all-in-one AC-coupled system is powerful, reliable, simple, and safe. It has a total usable energy capacity of 5.0 kWh and includes six embedded grid-forming microinverters with a 3.84 kVA continuous power rating. It provides backup capability, and installers can quickly design the right system size to meet the customer needs.

Dimensions in inches



Wall mounted

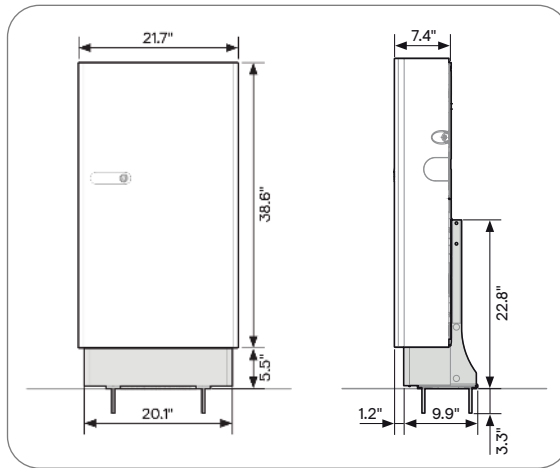

Floor mounted with pedestal
(sold separately)



LISTED



UL 9540A
Certified

Powerful

- Provides 3.84 kVA continuous and 7.68 kVA peak power
- Doubles the available power per kWh of prior generations of IQ Battery
- Includes six embedded IQ8D-BAT Microinverters

Reliable

- 15-year limited warranty
- Cools passively with no moving parts or fans
- Uses wired communication for fast and consistent connection
- Updates software and firmware remotely

Simple

- Fully integrated AC battery system
- Installs and commissions easily
- Supports Backup, Self-Consumption, and time-of-use (TOU) modes
- Offers homeowners remote monitoring and control from the Enphase App
- Field replaceable components

Safe

- Evaluated to UL 9540A for large scale fire testing and reduced separation distance as required in 2021 IRC R328.3.1, 2021 IFC 1207.1.5, and 2023 NFPA 855 15.3.1 and 9.1.5.¹
- Uses lithium iron phosphate (LFP) chemistry for maximum safety and longevity

¹Follow all installation instructions and local codes and requirements of the Authority Having Jurisdiction (AHJ) when installing Enphase ESS.

IQ Battery 5P

MODEL NUMBER	
IQBATTERY-5P-1P-NA	The IQ Battery 5P system with integrated IQ Microinverters and battery management system (BMS) with battery controller
WHAT'S IN THE BOX	
IQ Battery 5P unit	IQ Battery 5P unit (B05-T02-US00-1-3)
ID cover and conduit cover	IQ Battery 5P cover with two conduit covers for the left and right sides of the unit
Bottom mounting bracket and top shield	Bottom mounting bracket for mounting the battery on the wall. One top shield is required for UL9540A
M5 seismic screws	Two M5 seismic screws for securing the battery unit on the bottom mounting bracket
M4 grounding screws	Two M4 grounding screws for securing the top shield on the bottom mounting bracket
M5 ID cover grounding screws	Two M5 ID cover grounding screws for the EMI/EMC requirement
Cable ties	Six cable ties for securing field cables to the unit
Control (CTRL) connector	Spare CTRL connector without resistor for CTRL wiring
Control (CTRL) connector with resistor	Spare CTRL connector with resistor for CTRL wiring
Quick Install Guide (QIG)	QIG for IQ Battery unit installation instructions
OPTIONAL ACCESSORIES AND REPLACEMENT PARTS	
IQ8D-BAT-RMA	IQ8D-BAT Microinverter for field replacement
B05-T02-US00-1-3-RMA	IQ Battery 5P Battery unit for field replacement
B05-CX-0550-O	IQ Battery 5P cover for field replacement
B05-PI-0550-O	IQ Battery 5P pedestal mount
B05-CP-096-O	IQ Battery 5P conduit plates for field replacement. Includes one left-side and one right-side conduit plate
B05-WB-0543-O	IQ Battery 5P wall bracket for field replacement. Includes one bottom mounting bracket and one top shield
IQBATTERY-HNDL-5	IQ Battery 5P lifting handles. Includes one left-side and one right-side lifting handle
B05-ACFB-080-O	IQ Battery 5P AC filter board for field replacement
B05-BMSNA-0490-O	IQ Battery 5P BMS board for field replacement
B05-CANB-063-O	IQ Battery 5P control communication board for field replacement
B05-NICS-0524-O, B05-NUCS-0524-O	IQ Battery 5P control switch is preinstalled on the wiring cover for field replacement
OUTPUT [AC]	
	@240 VAC ²
Rated (continuous) output power	3.84 kVA
Peak output power	7.68 kVA (3 seconds), 6.14 kVA (10 seconds)
Nominal voltage/range	240/211–264 VAC
Nominal frequency/range	60/57–63 Hz
Rated output current (@240 VAC)	16 A
Peak output current (@240 VAC)	32 A (3 seconds), 25.6 A (10 seconds)
Load start capability	Up to 48 A LRA ³
Power factor (adjustable)	0.85 leading...0.85 lagging
Maximum units per 20 A branch circuit	One unit (single-phase)
Maximum conductor size supported	3 AWG
Overcurrent protection device (OCPD) for 3 AWG cable	80 A
Interconnection	Single-phase
AC round-trip efficiency ⁴	90%

²Supported in both grid-connected and backup/off-grid operation

³ Load start capability may vary

⁴ AC to the battery to AC at 50% power rating

IQ Battery 5P

BATTERY

Total capacity	5.0 kWh
Usable capacity	5.0 kWh
DC round-trip efficiency	96%
Nominal DC voltage	76.8 V
Maximum DC voltage	86.4 V
Ambient operating temperature range (charging)	-20°C to 50°C (-4°F to 122°F) non-condensing
Ambient operating temperature range (discharging)	-20°C to 55°C (-4°F to 131°F) non-condensing
Optimum operating temperature range	0°C to 30°C (32°F to 86°F)
Chemistry	Lithium iron phosphate (LFP)

MECHANICAL DATA

Dimensions (HxWxD)	980 mm x 550 mm x 188 mm (38.6 in x 21.7 in x 7.4 in)
Lifting weight	66.3 kg (146.1 lbs)
Total installed weight	78.9 kg (174 lbs)
Enclosure	Outdoor-NEMA 3R
IQ8D-BAT Microinverter enclosure	NEMA type 6
Cooling	Natural convection
Altitude	Up to 2,500 meters (8,202 feet)
Mounting	Wall-mount or pedestal-mount (sold separately)

FEATURES AND COMPLIANCE

Compatibility	Compatible with IQ and M Series Microinverters, IQ System Controller 3/3G, IQ Combiner 5/5C, and IQ Gateway for grid-tied and backup operation
Communication	Wired control communication
Services	Backup, Self-Consumption, TOU, and NEM integrity
Monitoring	Enphase Installer Platform and Enphase App monitoring options; API integration
Compliance	CA Rule 21 (UL 1741-SA), IEEE 1547:2018 (UL 1741-SB, 3rd Ed.) CAN/CSA C22.2 No. 107.1-16 UL 9540 ⁵ , UL 9540A, UN 38.3, UL 1998, UL 991, NEMA Type 3R, AC156 EMI: 47 CFR, Part 15, Class B, ICES 003 Cell module: UL 1973, UN 38.3 Inverters: UL 62109-1, IEC 62109-2

LIMITED WARRANTY

Limited warranty	>60% capacity, up to 15 years or 6,000 cycles ⁶
------------------	--

⁵ Following local standards, choose a well-ventilated, non-habitable, indoor location (like a 2-car garage) or in an outdoor location, which is out of direct sunlight and where the ambient temperature and humidity are within -4°F to 113°F (-20°C to 45°C) and 5% to 95% RH, non-condensing.

⁶ Whichever occurs first. Restrictions apply

Revision history

REVISION	DATE	DESCRIPTION
DSH-00010-3.0	September 2023	<ul style="list-style-type: none">• Updated product images.• Editorial updates.
DSH-00010-2.0	July 2023	<ul style="list-style-type: none">• Added battery isometric view on the first page.• Editorial updates.
DSH-00010-1.0	May 2023	Initial release.